

VECTECH 990VC REWORK STATION

Instruction Manual

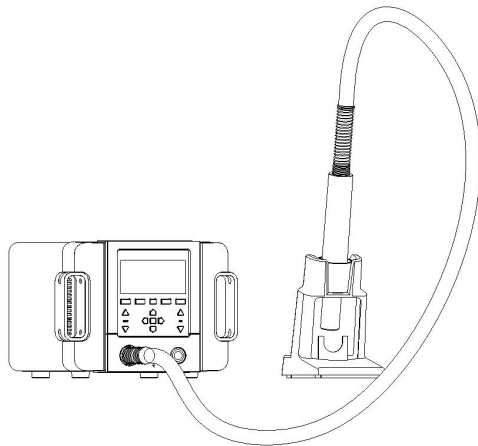

Thank you for purchasing our products. Please keep the instruction manual properly for future reference.

Contents

1. Safety Instructions.....	1
2. Overview.....	2
3. Product Characteristics.....	2
4. Product Specifications.....	3
5. Functional Descriptions.....	4
5.1. Dimensions.....	4
5.2. Part Descriptions.....	5
5.3. Button Descriptions.....	5
5.4. Function Descriptions of the Main Interface.....	6
6. Temperature/Airflow/Channel Settings.....	7
6.1. Temperature Settings.....	7
6.2. Airflow Settings.....	7
6.3. Channel Settings.....	8
7. Setting of Furnace Temperature Mode.....	8
8. Password Settings.....	9
9. Sleep/Wake Up.....	9
10. Temperature Calibration.....	10
11. Instructions for the Heater Replacment.....	11
11.1. Steps of removing the Heater.....	11
11.2. Steps of replacing the Heater.....	11
12. Installation and Disassembly of Nozzle.....	12
13. Troubleshooting.....	13
14. Voice Control File.....	13

1.Safety Instructions

CAUTION

- During the installation and use of this product, all electrical safety regulations of the country and regions must be strictly observed.
- The power supply must be disconnected when disassembling the product. Do not operate with power on.
- If the product does not work properly, please contact the supplier or our company, and do not disassemble or change the product in any way. We are not responsible for any problems caused by unauthorized maintenance or modification.

WARNING

- Don't install the product in a place where the surface is easy to shake or be impacted, as it may damage the product.
- Don't place the product in places where it may be exposed to rain or moisture.
- The product should be used away from places where there is magnetic interference.
- Don't use in flammable and explosive environments.
- Pay attention to the air outlet and its surroundings. High temperature operation, be careful of burns.
- Power supply should be turned off during breaks or when finished to avoid safety accidents.
- Please keep the air outlet unblocked and ensure there is no obstruction.
- Check and maintain the product regularly. Do not use the product when it is damaged, especially when the power cord is damaged.
- The handle must be correctly placed on the holder when not working, and do not replace it on the workbench.
After operation, the unit can be turned off only when it is cooled below 100 °C (in the sleep state).
- Please unplug the power cord when the product is not used for a long time.

2.Overview

This product features a brushless eddy current blower for air output, electric heating wire for heating, K-type sensor for temperature measurement, MCU chip control circuit for precise temperature control, and color LCD screen for temperature and airflow display. It is suitable for rework on various components, such as SMD, SOP, SOG, etc., and can be applied in heat shrinkage, drying, paint removal, adhesive removal, thawing, preheating, disinfection, adhesive soldering, and others.

3.Product Characteristics

- Color LCD display, with numerical mode or curve mode to display heating parameters.
- Support password protection and button lock.
- 4 channels of CH1, CH2, CH3 and CH4 are available to separately set the airflow rate and temperature.
- The intelligent desoldering holder includes a magnetic switch that enables automatic sleep. The handle automatically stops heating when it is placed back to the holder to extend the service life of heater.
- Closed-loop sensor, and the microcomputer zero cross temperature control to realize high power, rapid heating, and with accurate and stable temperature adjustment.
- Brushless vortex blower with adjustable airflow rate in wide range for various heating purposes.

4.Product Specifications

Product Model	990VC
Power	1300W
Working Voltage	AC110V
Temperature Range	50°C~550°C
Airflow Range	Scale 1~200
Max Airflow Rate	70L/min
Dimensions(L×W×H)	214*235*159mm
Weight	About 4.3kg

5.Functional Descriptions

5.1.Dimensions

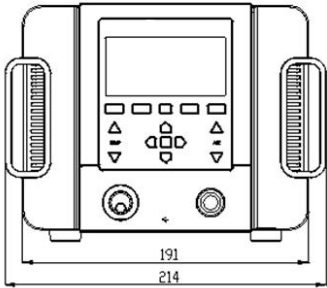
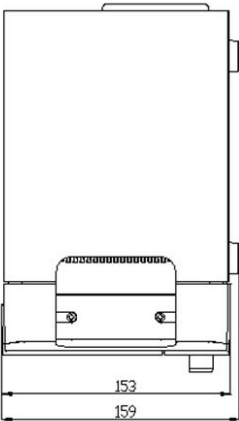
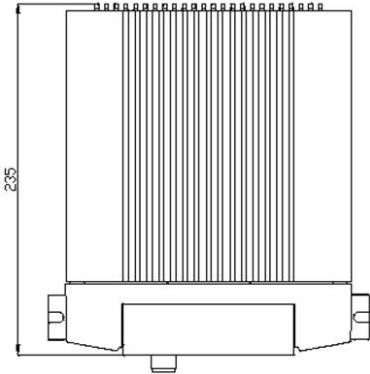

Unit: mm

5.2.Part Descriptions

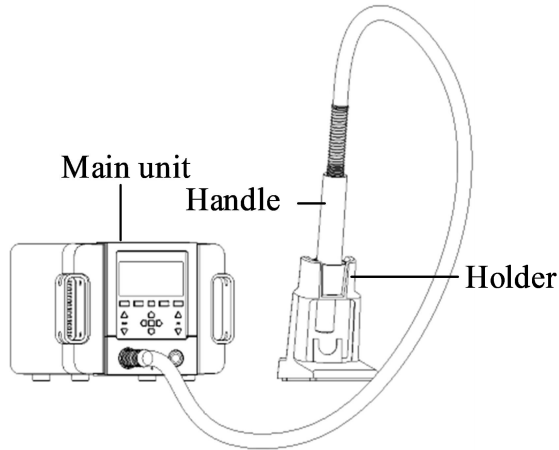

5.3.Button Descriptions

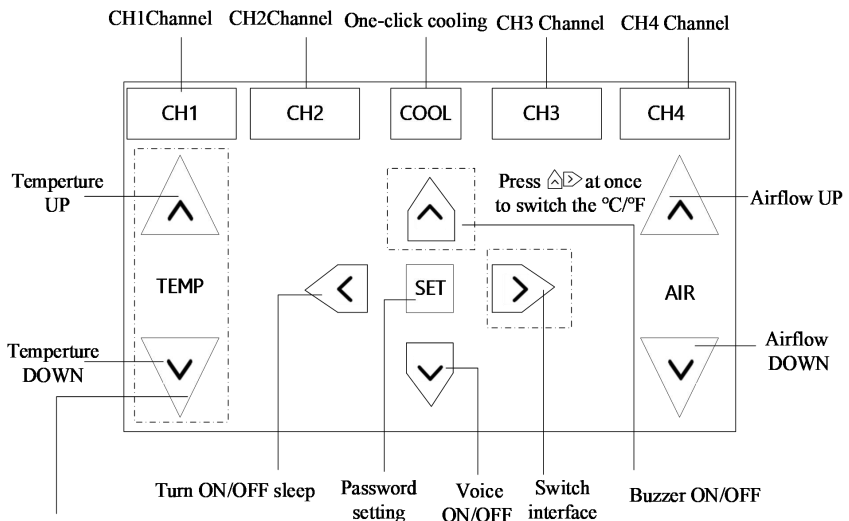

Press the temperature UP/Down buttons at once to enter the temperature calibration mode

Note: A prompt will pop-up when each function is enable/disabled (There is no pop-up prompt for switching between Chinese and English)

5.4.Function Descriptions of the Main Interface

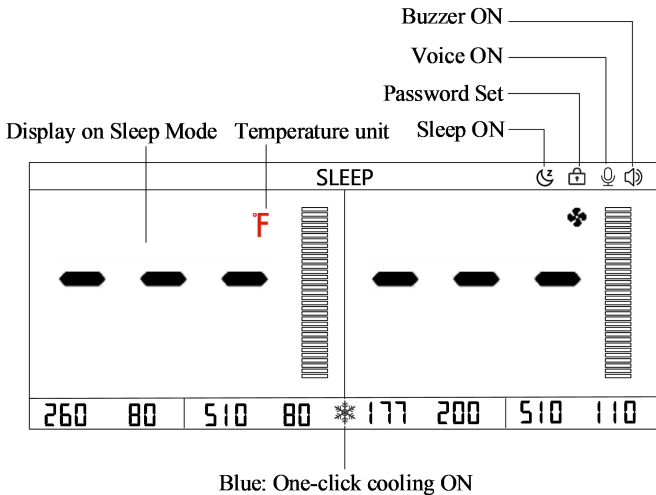
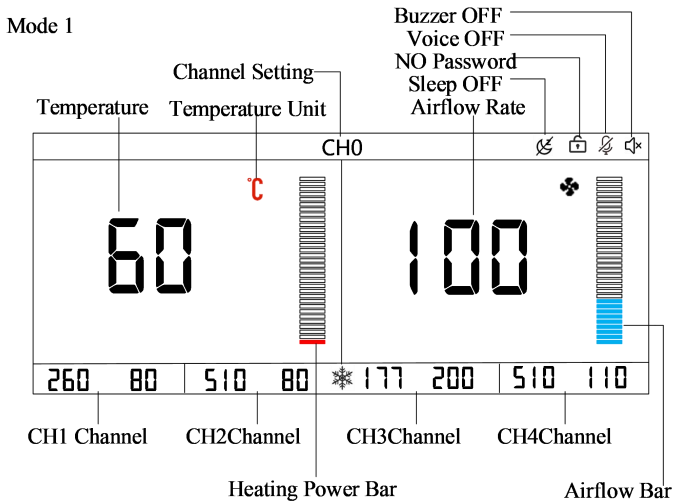

Mode 2

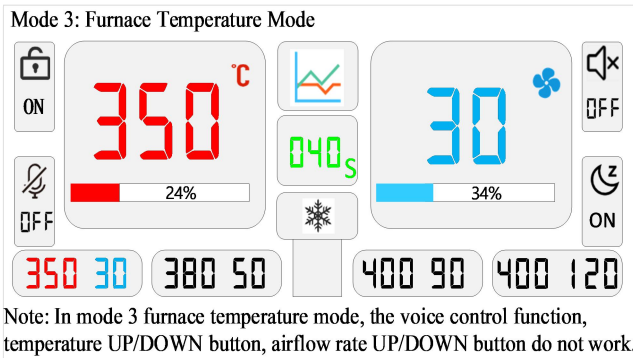
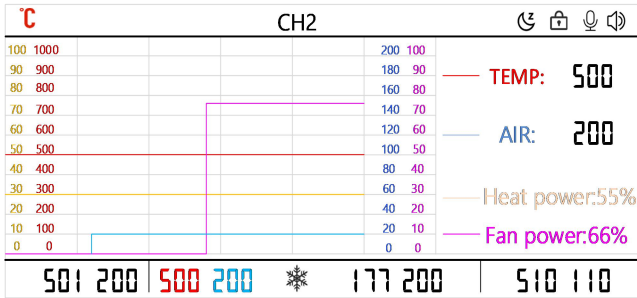

6. Temperature/Airflow/Channel Settings

6.1. Temperature Settings

Press "▲" or "▼" of TEMP once, the temperature goes up or down by 1°C; long press for quick adjustment.

6.2. Airflow Settings

Press "▲" or "▼" of AIR once, the airflow scale goes up or down by 1; long press for quick adjustment.

6.3.Channel Settings

Press the CH1, CH2, CH3, or CH4 to select the corresponding channel from 1~4. When the temperature and airflow settings are finished, long press CH1~CH4 to confirm and save the parameters.

7.Setting of Furnace Temperature Mode

In mode 3 furnace temperature mode, long press CH1, CH2, CH3 or CH4 to enter the parameter setting interface.

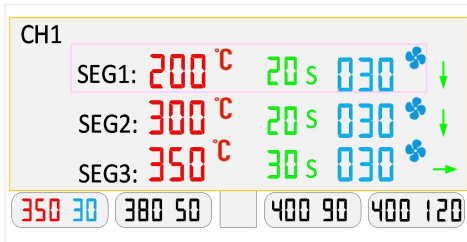

▷◁ In the furnace temperature mode, time +/- button

△▽ In the furnace temperature mode, switch the temperature segment

The setting of temperature and airflow rate are the same as 6.1 and 6.2. Press the ▷◁ buttons respectively to increase and decrease the time. Press the △▽ buttons respectively to switch the temperature segment. Long press SET or short press the current channel button to exit.

Take the picture below as an example:

You can set 3 temperature segments in furnace temperature mode. It starts timing when the first temperature segment reaches the set temperature at 200 °C. After 20 seconds, it reaches the second segment at 300°C. And then it continues to heat for 20 seconds to reach the third segment at 350 °C and remains for 30 seconds. When the set time (Cumulative time 70S) is reached it beeps, indicating a working cycle ends. Then press CH1 to start cooling, when the temperature reaches

the set value of the first temperature segment (200 °C), the above settings will repeat.



8.Password Settings

The initial password is "000". At this point the system is unlocked, and settings for functions and channels are available.

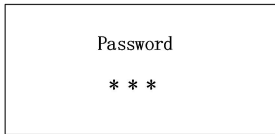
1) Long press the "SET" key to go to password setting page (Initial password is "000").



Password
* * *

2) Press the " " or " " to change the digit, and " " to move into the next digit. When finished, press SET to confirm.

3) Input the new password and press SET to confirm.

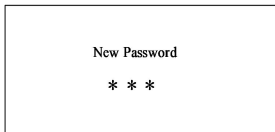

New Password
* * *

9.Sleep/Wake Up

1) When the handle is properly placed on the holder, the unit automatically enters the cooling state; and the unit enters the sleep mode instantly when the displayed temperature drops to 100 °C.

2) When the handle is removed from the holder, the system resumes to work instantly.

10. Temperature Calibration

The temperature should be recalibrated every time the heating element is replaced.

- 1) Set the temperature of the unit to 300°C before calibration.
- 2) When the value of temperature is stable, measure the air outlet temperature of the handle with QUICK 196 and record the reading.
- 3) Then long press the "▲" and "▼" of TEMP at once to enter the temperature calibration mode.

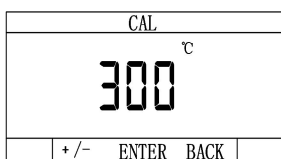

- 4) Press the "▲" and "▼" of TEMP to change the digit, then press "COOL" to confirm.

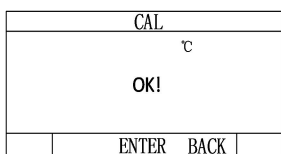

- 5) Repeat the above steps to calibrate until displaying no temperature error.

Note: If QUICK196 is not available, it is recommended to place the temperature measuring device of the thermometer external sensor 3~5mm away from the nozzle for temperature measurement.

11.Instructions for the Heater Replacment

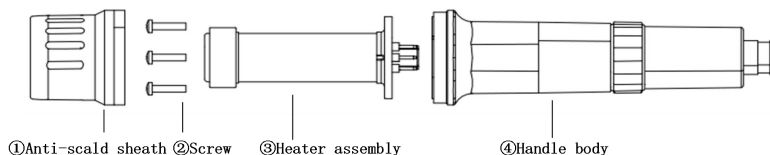

11.1.Steps of removing the Heater

- 1) Unscrew ① Anti-scalding sheath at the front of the handle.
- 2) Unscrew ② three screws fixing the heater steel pipe
- 3) Pull out the damaged ③ Heater assembly

 Note: All operating steps are performed with the power disconnected and the handle cooled

11.2.Steps of replacing the Heater

- 1) Align the pins of the new ③ Heater assembly with the socket of ④ Handle body and insert it vertically
- 2) Reinstall ② three screws that fix the steel pipe
- 3) Tighten ① Anti-scald sheath
- 4) After the heater is replaced, please do the following measurements:

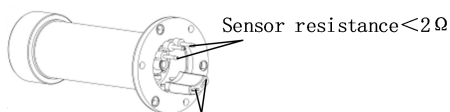

Heater resistance :
220V:40 Ω ($\pm 10\%$)
110V:10 Ω ($\pm 10\%$)

- 5) Calibrate the temperature, refer to soldering temperature calibration.

12. Installation and Disassembly of Nozzle

1) Installation: Insert the selected nozzle into the air outlet steel pipe of the handle, and then press the air nozzle into the air outlet steel pipe by hand, and make sure that the air nozzle has been clamped before use.

2) Removing: When disassembling the air nozzle, remove the handle from the air gun stand. There is a card slot between the air nozzle and the steel pipe of the air outlet. Put the handle on the air nozzle removal plate through the clamping groove, fix the air gun stand with one hand, and then gently pull the handle back to take out the nozzle.

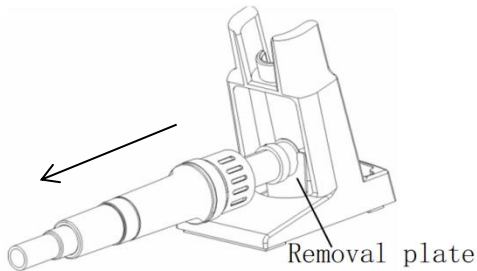

⚠ Note: Air nozzle can be customized
Replace the air nozzle after cooling down to avoid scalding.

13.Troubleshooting

No.	Error	Fault Descriptions
1	H-E	Faulty in the heater and need to be checked.
2	S-E	Faulty in the sensor and need to be checked.
3	F-E	Faulty in the fan and need to be checked.

14.Voice Control File

Control File 1 Commands

Commands	Reply Sentence
Hey Quick	Hey, what can I do for you
Heat ON	Heat ON
Heat OFF	Heat OFF
Volume DOWN	Volume DOWN
Volume UP	Volume UP
Set the channel one	Set the channel one
Set the channel two	Set the channel two
Set the channel three	Set the channel three

Set the channel four	Set the channel four
One degree UP	One degree UP
Two degrees UP	Two degrees UP
Five degrees UP	Five degrees UP
One degree DOWN	One degree DOWN
Two degrees DOWN	Two degrees DOWN
Five degrees DOWN	Five degrees DOWN
One scale UP	One scale UP
Two scales UP	Two scales UP
Five scales UP	Five scales UP
One scale DOWN	One scale DOWN
Two scales DOWN	Two scales DOWN
Five scales DOWN	Five scales DOWN
Temperature to Fifty	Temperature to Fifty
Temperature to Sixty	Temperature to Sixty
Temperature to Seventy	Temperature to Seventy
Temperature to Eighty	Temperature to Eighty
Temperature to Ninety	Temperature to Ninety
Temperature to One Hundred	Temperature to One Hundred
Temperature to One One Zero	Temperature to One One Zero
Temperature to One Two Zero	Temperature to One Two Zero
Temperature to One Three Zero	Temperature to One Three Zero
Temperature to One Four Zero	Temperature to One Four Zero
Temperature to One Five Zero	Temperature to One Five Zero
Temperature to One Six Zero	Temperature to One Six Zero
Temperature to One Seven Zero	Temperature to One Seven Zero
Temperature to One Eight Zero	Temperature to One Eight Zero

Temperature to One Nine Zero	Temperature to One Nine Zero
Temperature to Two Hundred	Temperature to Two Hundred
Temperature to Two One Zero	Temperature to Two One Zero
Temperature to Two Two Zero	Temperature to Two Two Zero
Temperature to Two Three Zero	Temperature to Two Three Zero
Temperature to Two Four Zero	Temperature to Two Four Zero
Temperature to Two Five Zero	Temperature to Two Five Zero
Temperature to Two Six Zero	Temperature to Two Six Zero
Temperature to Two Seven Zero	Temperature to Two Seven Zero
Temperature to Two Eight Zero	Temperature to Two Eight Zero
Temperature to Two Nine Zero	Temperature to Two Nine Zero
Temperature to Three Zero Zero	Temperature to Three Hundred
Temperature to Three One Zero	Temperature to Three One Zero
Temperature to Three Two Zero	Temperature to Three Two Zero
Temperature to Three Three Zero	Temperature to Three Three Zero
Temperature to Three Four Zero	Temperature to Three Four Zero
Temperature to Three Five Zero	Temperature to Three Five Zero
Temperature to Three Six Zero	Temperature to Three Six Zero
Temperature to Three Seven	Temperature to Three Seven
Temperature to Three Eight Zero	Temperature to Three Eight Zero
Temperature to Three Nine Zero	Temperature to Three Nine Zero
Temperature to Four Hundred	Temperature to Four Hundred
Temperature to Four One Zero	Temperature to Four One Zero
Temperature to Four Two Zero	Temperature to Four Two Zero
Temperature to Four Three Zero	Temperature to Four Three Zero

Temperature to Four Four Zero	Temperature to Four Four Zero
Temperature to Four Five Zero	Temperature to Four Five Zero
Temperature to Four Six Zero	Temperature to Four Six Zero
Temperature to Four Seven Zero	Temperature to Four Seven Zero
Temperature to Four Eight Zero	Temperature to Four Eight Zero
Temperature to Four Nine Zero	Temperature to Four Nine Zero
Temperature to Five Hundred	Temperature to Five Hundred
Temperature to Five One Zero	Temperature to Five One Zero
Temperature to Five Two Zero	Temperature to Five Two Zero
Temperature to Five Three Zero	Temperature to Five Three Zero
Temperature to Five Four Zero	Temperature to Five Four Zero
Temperature to Five Five Zero	Temperature to Five Five Zero
Temperature to Five Six Zero	Temperature to Five Six Zero
Temperature to Five Seven Zero	Temperature to Five Seven Zero
Temperature to Five Eight Zero	Temperature to Five Eight Zero
Temperature to Five Nine Zero	Temperature to Five Nine Zero
Temperature to Six Hundred	Temperature to Six Hundred
Temperature to Six One Zero	Temperature to Six One Zero
Temperature to Six Two Zero	Temperature to Six Two Zero
Temperature to Six Three Zero	Temperature to Six Three Zero
Temperature to Six Four Zero	Temperature to Six Four Zero
Temperature to Six Five Zero	Temperature to Six Five Zero
Temperature to Six Six Zero	Temperature to Six Six Zero
Temperature to Six Seven Zero	Temperature to Six Seven Zero
Temperature to Six Eight Zero	Temperature to Six Eight Zero
Temperature to Six Nine Zero	Temperature to Six Nine Zero

Temperature to Seven Hundred	Temperature to Seven Hundred
Temperature to Seven One Zero	Temperature to Seven One Zero
Temperature to Seven Two Zero	Temperature to Seven Two Zero
Temperature to Seven Three	Temperature to Seven Three
Temperature to Seven Four Zero	Temperature to Seven Four Zero
Temperature to Seven Five Zero	Temperature to Seven Five Zero
Temperature to Seven Six Zero	Temperature to Seven Six Zero
Temperature to Seven Seven	Temperature to Seven Seven
Temperature to Seven Eight Zero	Temperature to Seven Eight
Temperature to Seven Nine Zero	Temperature to Seven Nine Zero
Temperature to Eight Hundred	Temperature to Eight Hundred
Temperature to Eight One Zero	Temperature to Eight One Zero
Temperature to Eight Two Zero	Temperature to Eight Two Zero
Temperature to Eight Three Zero	Temperature to Eight Three Zero
Temperature to Eight Four Zero	Temperature to Eight Four Zero
Temperature to Eight Five Zero	Temperature to Eight Five Zero
Temperature to Eight Six Zero	Temperature to Eight Six Zero
Temperature to Eight Seven Zero	Temperature to Eight Seven
Temperature to Eight Eight Zero	Temperature to Eight Eight Zero
Temperature to Eight Nine Zero	Temperature to Eight Nine Zero
Temperature to Nine Hundred	Temperature to Nine Hundred
Temperature to Nine One Zero	Temperature to Nine One Zero
Temperature to Nine Two Zero	Temperature to Nine Two Zero
Temperature to Nine Three Zero	Temperature to Nine Three Zero
Temperature to Nine Four Zero	Temperature to Nine Four Zero
Temperature to Nine Five Zero	Temperature to Nine Five Zero

Minimum airflow rate	Minimum airflow rate
Airflow rate to Ten	Airflow rate to Ten
Airflow rate to Twenty	Airflow rate to Twenty
Airflow rate to Thirty	Airflow rate to Thirty
Airflow rate to Forty	Airflow rate to Forty
Airflow rate to Fifty	Airflow rate to Fifty
Airflow rate to Sixty	Airflow rate to Sixty
Airflow rate to Seventy	Airflow rate to Seventy
Airflow rate to Eighty	Airflow rate to Eighty
Airflow rate to Ninety	Airflow rate to Ninety
Airflow rate to One Hundred	Airflow rate to One Hundred
Airflow rate to One One Zero	Airflow rate to One One Zero
Airflow rate to One Two Zero	Airflow rate to One Two Zero
Airflow rate to One Three Zero	Airflow rate to One Three Zero
Airflow rate to One Four Zero	Airflow rate to One Four Zero
Airflow rate to One Five Zero	Airflow rate to One Five Zero
Airflow rate to One Six Zero	Airflow rate to One Six Zero
Airflow rate to One Seven Zero	Airflow rate to One Seven Zero
Airflow rate to One Eight Zero	Airflow rate to One Eight Zero
Airflow rate to One Nine Zero	Airflow rate to One Nine Zero
Airflow rate to Two Hundred	Airflow rate to Two Hundred

Control File 2 Study Command

Commands	Reply Sentence
Hey Quick	Hey, what can I do for you
Study Wake	Please follow the prompts to study wake up words in a quiet environment
Study Command	Please follow the prompts to study command words in a quiet environment
Study Next	Ok
Study Again	Please follow the prompts to study command words in a quiet environment
Quit Study	Exit learning mode
I Want-to-deleted	Is it the learned wake up word or command word that needs to be deleted
Deleted Wake	Deletion Succeeded
Deleted Command	Deletion Succeeded
Deleted All	Deletion Succeeded
Exit Deleted	Exit delete mode

