

VECTECH 443D STATIC ELIMINATOR

Instruction Manual

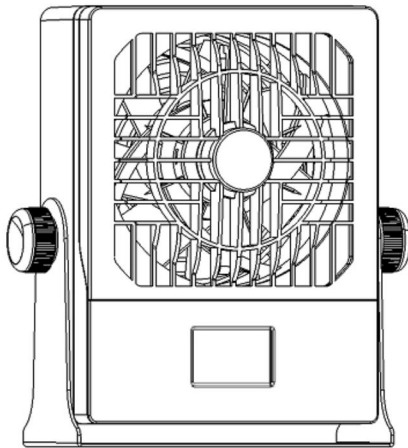

Thank you for purchasing our products. Please keep the instruction manual properly for future reference.

Contents

1. Safety Instructions.....	1
2. Overview.....	2
3. Product Characteristics.....	2
4. Product Specifications.....	3
5. Static Elimination Time Test.....	4
6. Functional Specifications.....	5
6.1. Dimensions.....	5
6.2. Part Descriptions.....	6
6.3. Key Descriptions.....	7
6.4. Function Descriptions of the Main Interface.....	8
7. Interface Descriptions.....	9
8. Operations.....	10
9. Menu Settings.....	11
9.1. Power-on Cleaning.....	11
9.2. Timed Cleaning.....	11
9.3. Device Address.....	12
9.4. Parameter Management.....	12
9.5. Language Settings.....	13
9.6. Password Settings.....	13
10. Maintenance.....	14
10.1. Cleaning the Ion Emitter.....	14
10.2. Ion Output Measurement.....	14
11. Disassembly and Assembly Instructions of Front Windshield.	15
12. Troubleshooting.....	16

1.Safety Instructions



CAUTION

- During the installation and use of this product, all electrical safety regulations of the country and regions must be strictly observed.
- The power supply must be disconnected when disassembling the product. Do not operate with power on.
- If the product does not work properly, please contact the supplier or our company, and do not disassemble or change the product in any way. We are not responsible for any problems caused by unauthorized maintenance or modification.



WARNING

- The product should be used away from places where there is magnetic interference.
- Don't install the product in a place where the surface is easy to shake or be impacted, as it may damage the product.
- Don't place the product in places where it may be exposed to rain or moisture.
- Don't use in flammable and explosive environments.
- After power on, don't touch the ion emitter.
- Please keep the air outlet and inlet unblocked to ensure there is no obstruction.
- In order to avoid electric shock and ensure the performance of static elimination, please make sure the ion grounding terminal is completely grounded.
- Please unplug the power cord when the product is not used for a long time.

2.Overview

This static eliminator adopts the high-voltage corona discharge method, generating a large number of positive and negative ions, which are driven by the fan to neutralize the charges on the object to achieve static elimination.

3.Product Characteristics

- Plastic housing in fine appearance, portable and light with adjustable angle.
- The front windshield and the ion emitter assembly can be flexibly disassembled for easy maintenance and replacement.
- Support the ion emitter self-cleaning, and the cleaning time can be set flexibly.
- Fault alarm function, prompt for abnormalities of front windshield, fan, and high pressure.
- System configuration data supports USB import and export, reducing setup time.
- Support RS485 wired network .
- Air volume grades to adjust from 0 to 9, select a proper one according to the settings for better adaptability.
- Automatic ion balance, more stable.

4.Product Specifications

Product Model	443D
Power Consumption	20W
Input Voltage	DC 24V±5%
Ion Balance	±10V (Test distance of 300mm)
Static Elimination Time	≤1.2s (Test distance of 300mm)
Working Environment	0~50°C, 40%~60%RH
High-voltage Output	High frequency±2.2kV
Fan Flow Rate	4.6m ³ /min (Max)
Dimension(L*W*H)	186*87*200mm
Weight	About 1.1kg

5.Static Elimination Time Test

Test Distance	30cm	60cm	90cm	120cm
Positive Decay Time	1.0s	1.5s	2.0s	3.0s
Negative Decay Time	1.2s	2.0s	3.0s	4.0s
Ion Balance	±10V	±10V	±10V	±10V

Note:

- 1) The test is performed under the environment of $22\pm 2^{\circ}\text{C}$ & $45\pm 5\%$ RH.
- 2) The ion balance and static elimination time are tested in line with the standard (ANSI/ESD-S20.20-2021).
- 3) The static elimination time is tested according to the table above from 1000V to 100V.
- 4) The above test data may vary due to changes in temperature, humidity, and surrounding environment.

6.Functional Specifications

6. 1. Dimensions

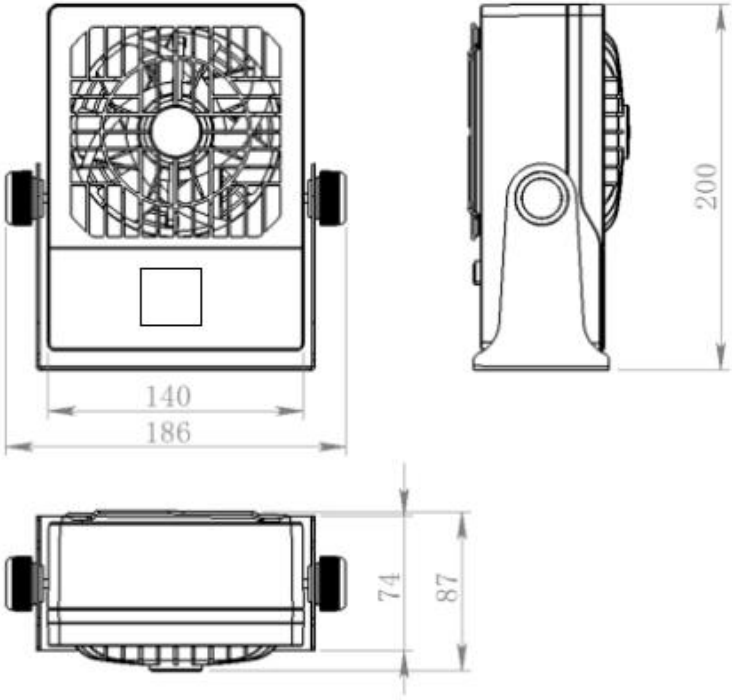

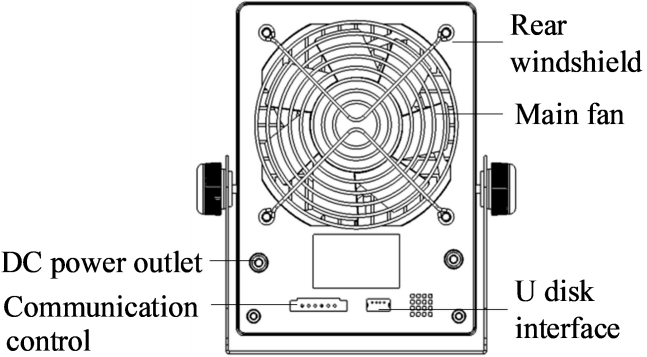
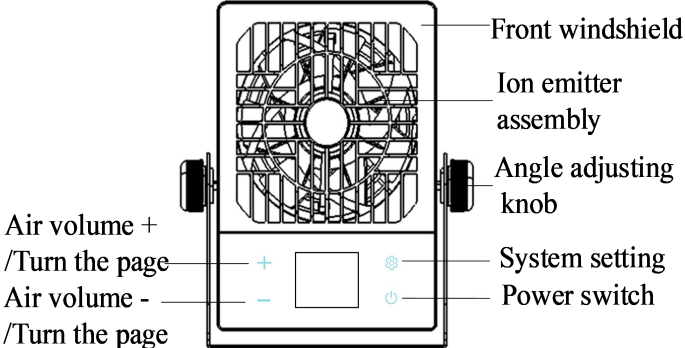

Unit: mm

6. 2. Part Descriptions





6. 3. Key Descriptions

Key	Function
	Main interface: air volume increase and decrease Setting interface: turn the page
	Power on: long press to turn on Power off: long press to turn off
	Main interface: short press to enter the setting interface, long press to start self-cleaning Setting interface: short press to confirm, long press to exit

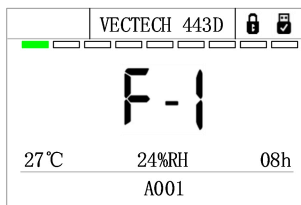
6. 4. Function Descriptions of the Main Interface



Symbols	Descriptions
VECTECH 443D	Product model
27°C	Ambient temperature
24%RH	Ambient humidity
08h	Scheduled clean time (hours)
F-1	Air volume grade
A001	Local address (RS485)
	Keys are locked
	USB flash disk connected

7.Interface Descriptions



NO.	Function	Descriptions
1	B	RS485 communication bus B
2	A	RS485 communication bus A
3	OUT	Alarm output: When the leakage signal is output and the static eliminator is abnormal, the OUT is shorted to the negative pole of the power supply.
4	IN	External control input ON/OFF: ① The IN is shorted to the negative pole of the power supply, and the static eliminator works normally. ② The IN is disconnected from the negative pole of the power supply, and the static eliminator is suspended. Note: When the static eliminator detects a short circuit signal, it switches to external control mode.
5	GND	24V Negative pole of power supply
6	VCC	24V Positive pole of power supply

8.Operations

- 1) Connect the power cord and grounding wire.
- 2) Press the power switch, and the static eliminator will turn on and start self-cleaning. The power switch has a memory function, and the next time when the power is on, it will automatically determine whether to turn on according to the last switch state.
- 3) Based on the actual usage scenario, select an appropriate air volume grade, adjust the scheduled cleaning time, and the power-on cleaning is ON by default.
- 4) Set the local address and wireless network configuration according to the communication mode.



9.Menu Settings

9. 1. Power-on Cleaning

- 1) Press the "  " key to enter the power-on cleaning enabling interface. Press the "+" or "-" key to turn on /off the function.
- 2) Press "  " to confirm after selection.

SET	
BootClean	<input checked="" type="checkbox"/> ON <input type="checkbox"/> OFF
CleanTime	
Address	
USB File	
Language	

9. 2. Timed Cleaning

- 1) Press "+" and "-" to select the timed cleaning menu.
- 2) Press the "  " key to enter the clean time setting, and press the "+" or "-" key to set the time. Time setting range: 0 ~ 999h.
- 3) Press "  " to confirm after setting.

SET	
BootClean	
CleanTime	08h
Address	
USB File	
Language	

9. 3. Device Address

- 1) Press "+" or "-" to select the device address menu.
- 2) Press the "⚙️" key to enter the device address setting, and press the "+" or "-" key to set the address. Address range is from 001 ~ 247.
- 3) Press "⚙️" to confirm after setting.

SET	
BootClean	
CleanTime	001
Address	
USB File	
Language	

9. 4. Parameter Management

- 1) Insert the USB disk into the USB interface of the static eliminator.
- 2) Press "+" or "-" to select the parameter management menu.
- 3) Press the "⚙️" key to enter the parameter management, and press the "+" or "-" key to select the import or export of system setting parameters.
- 4) Press "⚙️" to confirm after selection.

SET	
BootClean	
CleanTime	<input checked="" type="checkbox"/> USB to MCU
Address	<input type="checkbox"/> MCU to USB
USB File	
Language	

9. 5. Language Settings

- 1) Press the "+" and "-" keys to enter the language setting menu.
- 2) Press the "⚙️" key to enter the language selection, and press the "+" or "-" key to select 中文简体 ,English ,or 中文繁體.
- 3) After setting, press "⚙️" to confirm.

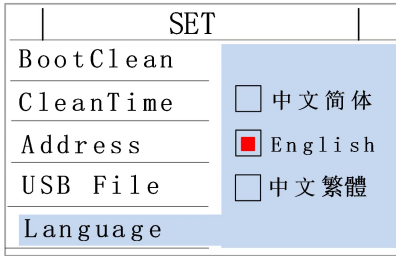

9. 6. Password Settings

- 1) Press "+" and "-" to enter the password setting.
- 2) Press the "⚙️" key to enter the password setting interface, press the "+" or "-" key to input the old password (original password 000), and press "⚙️" to enter the new password input interface. Press the "+" or "-" key to select the value (0 ~ 9). Press the "⚙️" key to change the digit.
- 3) After setting, long press "⚙️" to confirm and exit.

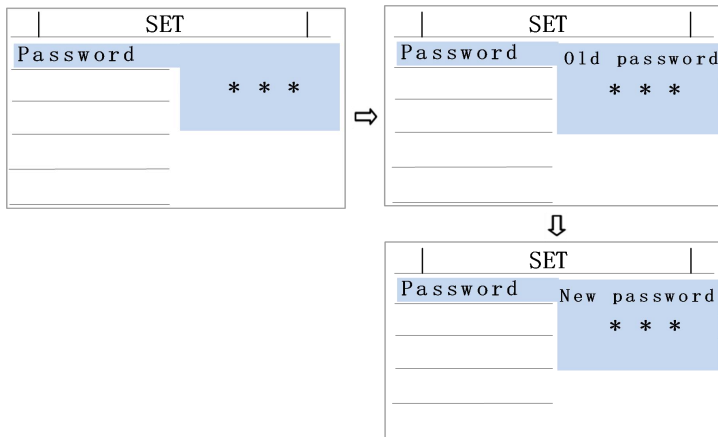

10.Maintenance

10. 1. Cleaning the Ion Emitter

- 1) It is recommended to check and clean the ion emitter regularly.
- 2) Remove the front cover. (Refer to 11.Disassembly and Assembly Instructions of Front Windshield)
- 3) Gently wipe the ion emitter using a cleaning cotton swab with alcohol.

 **Note:** Be sure to turn off the power during cleaning and maintenance.

10. 2. Ion Output Measurement

Measure the static elimination time and ion balance with the VECTECH 498 charge plate monitor.

11. Disassembly and Assembly Instructions of Front Windshield

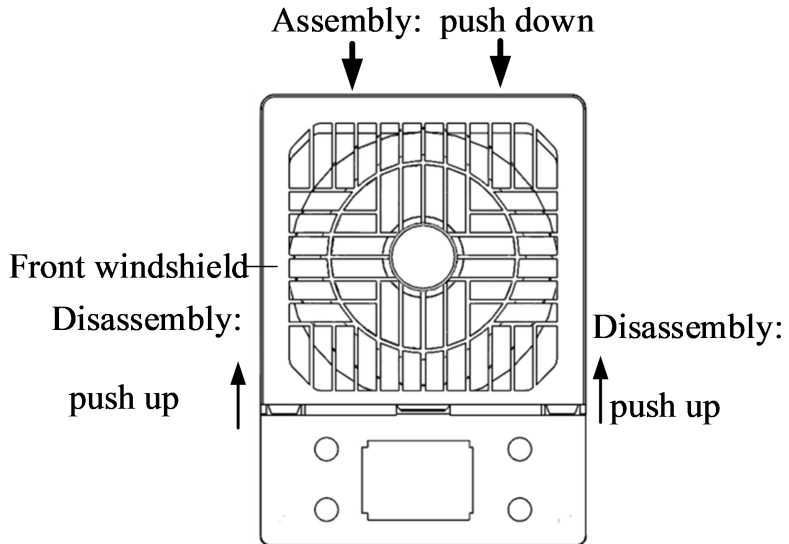

12.Troubleshooting

NO.	Error display	Error description
1	The front windshield is abnormal	Installation is not in place, or artificial disassembled.
2	Fan is abnormal	Abnormal speed or fan blockage.
3	High voltage is abnormal	Circuit abnormality in high voltage ion generation.

