

VECTECH 496

ELECTROSTATIC FIELDMETER

OPERATION MANUAL

Thank you for purchasing our electrostatic field meter.
Please carefully read this manual before operating the system.
Store this manual in a safe, easily accessible place for future
reference.

Note:

- * Please accord to the “note” for preventing the meter from damage.**
- * Please not hit the sensor part.**
- * Please not wet the meter and not use the meter with wet hands.**
- * Please use the original parts when replacing the fittings.**
- * Please turn off the power supply when finishing using and take out the battery when not using in a period of time.**

1.Summary

This electrostatic field meter is a special meter for testing the static and can test the ion balance. It can test quickly and effectively the static with untouched sensor, such as plastic, chemical fiber, pelage and the static of the body and so on.

2.Product Instruction and Parts

Product instruction

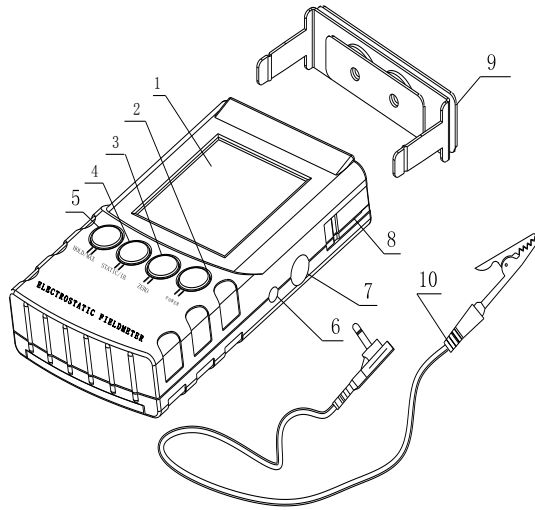

- | | |
|-----------------|--------------------------------|
| 1、LCD | 6、calibrating hole |
| 2、POWER key | 7、grounding jack to the meter |
| 3、ZERO key | 8、notch of testing ion balance |
| 4、STATIC/IB key | 9、ion balance testing plate |
| 5、HOLD/MAX key | 10、grounding line |

- 2 The meter cannot run when the voltage is lower. And in the testing process, the meter sounds firstly and turns off automatically. At the moment, it must replace a new battery.
- 3 Replace a new battery: move the lid and take out the valid battery. And then replace a new battery (refer to the picture).

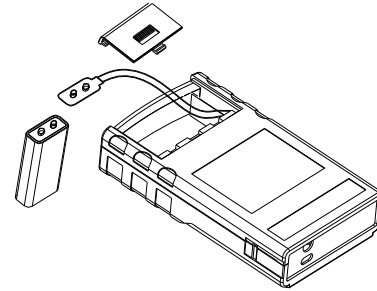





- Note:** * The meter can work about 12 hours continually when using a new battery. And please turn off the power supply when not using.
- * Do not replace the new battery in the testing process for protecting the meter from being damage.

- 6 Press “HOLD/MAX” key into hold process or max process when it is necessary to keep the testing value or maximal value.
- 7 Press “POWER” key to turn off the meter when finishing the test.

Note:

- * The measure precise is correlative with the measure distance between the sensor induces and the back testing board. So the ion balance testing board must be inserted to the setting position.
- * Do not touch the ion balance testing board when testing or else the voltage in the front testing board will be eliminated.

5. Replace the battery

1  means the voltage is full,  means the voltage is enough,  means the voltage is not enough,  means the voltage is near to end.

Display on the LCD

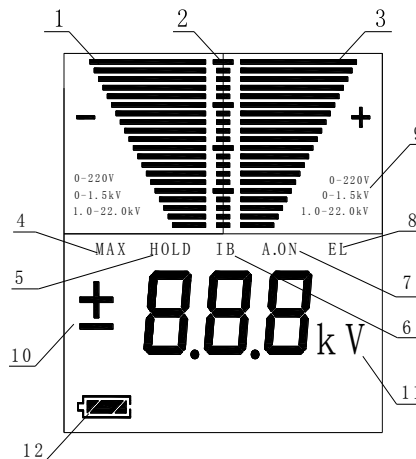

- | | |
|------------------------|-------------------|
| 1、negative measurement | 7、continuous work |
| 2、coordinate | 8、LCD lighting |
| 3、positive measurement | 9、measuring range |
| 4、MAX | 10、testing data |
| 5、HOLD | 11、unit |
| 6、ion balance testing | 12、battery range |

2.3 Parts

The meter includes following parts as the table. Please check all the parts are well and if the parts are damaged, please contact with the agents or our company.

NO.	Parts	Quantity
1	Electrostatic field meter	1
2	Testing plate of the ion balance	1
3	Grounding line	1
4	9VDC battery	1
5	Operation Manual	1
6	Maintaining card	1

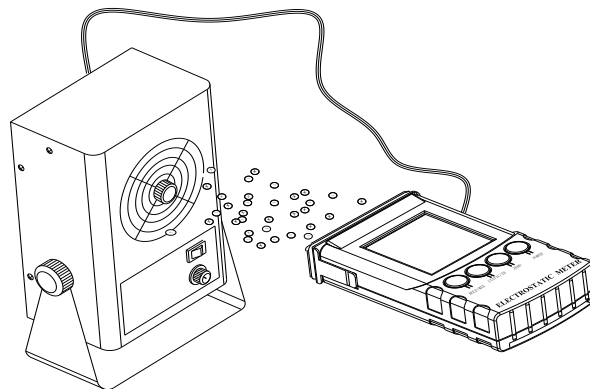

3.Specifications

Power supply: 9VDC

Display: LCD

Static testing range : low 0~±1.50KV

high 1~±22.0KV

(Auto –switch between low and high)

ion balance testing range: 0~±220V

measure distance(static): 25mm (±0.5mm)

- 1 Insert the ion balance testing plate to the notch (refer to the picture) and it must insert to the end.
- 2 Press “POWER” key to select the working mode and press “STATIC/IB” key into the ion balance testing process after the static testing state.
- 3 connect the front testing plate to the “ground of the meter” and zero if the displaying value is not zero (refer to the 4.2).
- 4 connect the “ground of the meter” to the grounding of the Static Eliminator device.

5 the Static Eliminator device such as ionic air blower and keep some distance to test the ion balance.

When it is necessary to keep the testing value or maximal value.

6 Press “power” key to turn off the meter when finishing the test.

Note: the measure precise is correlative with the measure distance (25mm). When the “+” is more clearer and the measure distance is more nearer 25mm.

4.6 Ion Balance Testing Instructions

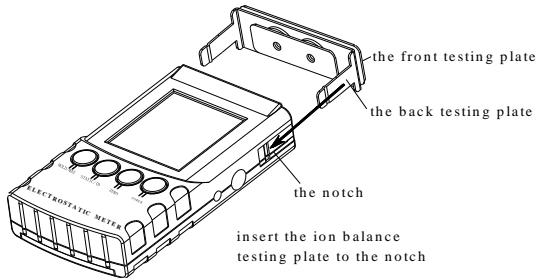

Testing precise: $\pm 10\%$

Waiting current: $< 3\mu\text{A}$

Working current: $< 15\text{mA}$

Surroundings: $0^\circ\text{C} \sim 50^\circ\text{C}$, humidity $< 80\%$

Surface: ESD safe

Size: $125\text{mm} \times 70\text{mm} \times 25\text{mm}$

Weight: 200g (including battery and testing plate of the ion balance)

4. Operation Instruction

Pressing “power” key to select the working mode and there are four modes to select. Refer to the following table.

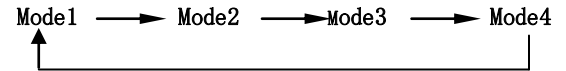

	Mode1	Mode 2	Mode 3	Mode 4
Pressing “power” time	1s-2.5s	2.5s-3.5s	3.5s-4.5s	4.5s-5s
LCD	display “1”	display “2” and “EL”	display “3” and “A.ON”	display “4”、 “EL” and “A.ON”
Sound	di	di	di-di-di	di-di-di
Mode state	Turn off the power supply after working five minutes.		Continuous work and turn off the power supply automatically (A.ON).	
	LCD without lighting	LCD with lighting (EL)	LCD without lighting	LCD with lighting (EL)

2 Manual turns off the meter: press the “power” key when working until displaying “OFF”.

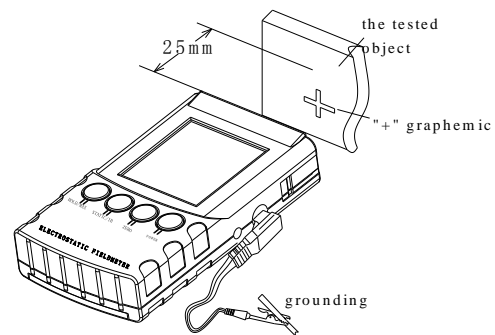

- 1 Press “power” key to select the working mode and then go into the static testing process.
- 2 Ground the meter.
- 3 Avoid objects with electricity and then zero if the display is not zero value (refer to the 4.2).
- 4 The front part of the meter is parallel to the tested object about 25mm and the displaying value on the LCD is the static value carried by the tested object. The measure distance is about 25mm when seeing a clear red “+” on the tested object.
- 5 Press “HOLD/MAX” key into hold process or max process

MAX: keep the current maximal value until testing more bigger value. In max process, lock the functions of “STATIC / IB” and “ZERO” until exiting the MAX process.

ENTER: press “HOLD/MAX” key until display “MAX” to max process.

EXIT: press “HOLD/MAX” key to exit the max process (without display “MAX”).

4.5 Static Testing Instructions

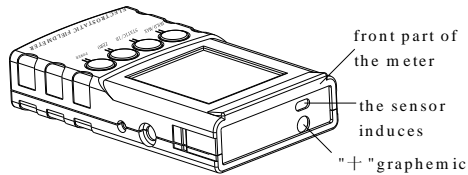

4.2 Zero

Note:

1) **Ground of the meter:** default 0 of the meter

*The grounding line is “Ground of the meter” when insert it into the grounding hole of the meter.

*The surface is ESD and it is “Ground of the meter”.

2) **Conductor:** the resistance of the meter is high and the body, water, wet some things, earth and some wall are conductors.

3) **Grounding:** ground to the earth.

Grounding of the meter: connect the “Ground of the meter” with the grounded things. The grounded thing is connecting to the earth. For example: some wall and bricks, some chairs and body wearing antistatic footwear and so on.

1 The meter must be zeroed before testing the static and the ion balance.

2 The zeroed methods of the static testing:

* Grounding first and then press “ZERO” key about two seconds and *test the grounding things to zero*. After un-pressing the key, the meter sounds and displays 0 if

zeroing successfully.

- * Grounding first and then press “ZERO” key about two seconds and avoid objects with electricity to zero. After un-pressing the key, the meter sounds and displays 0 if zeroing successfully.
- * Connect the conductor to the “Ground of the meter” first and then press “ZERO” key about two seconds and test the conductor to zero. After un-pressing the key, the meter sounds and displays 0 if zeroing successfully.

For example: one hand handholds the meter and put the other hand as conductor in front of the meter to zero.

3 The zeroed method of the ion balance testing:

Insert the ion balance testing plate firstly and then connect the “front testing plate” to the “Ground of the meter”. Press “ZERO” key about two seconds to zero. After un-pressing the key, the meter sounds and displays 0 if zeroing successfully.

4.3 switch between the static testing and the ion balance testing

1 the meter runs into the static testing after switching on the

power supply.

- 2 press “STATIC/IB” key to the ion balance testing (display “IB”).
- 3 press “STATIC/IB” key again to return to the static testing.



- 4 press “STATIC/IB” key again to the ion balance testing.

4.4 HOLD/MAX

HOLD: keep the current testing value for recording it. And lock the functions of “STATIC /IB” and “ZERO” until exiting the HOLD process.

ENTER: press “HOLD/MAX” key (less than 1.5s) to hold process (display “HOLD” after un-press the key).

EXIT: press “HOLD/MAX” key to exit the hold process (without display “HOLD”).